

A B C D E F

REV.	ECN NO.	DESCRIPTION	DATE	DESIGN
X0		新图制成	2021-10-07	LEO-HE
X1		新增产品规格	2021-12-20	LEO-HE

NOTES:
 1.MATERIALS: SEE BOM
 2.FINISH:TERMINAL:SEE PART NO;
 3.PARTING LINE FLASH SHALL NOT EXCEED 0.3MM.
 4.DEBURR AND BREAK SHARP EDGES UNLESS
 5.SPEC. PLS. REFER TO SPEC-PH3001H-XXXXX:
 6.PART NO.: PH3001H-XX X X X X

WITHOUT "H" : WITH HALOGEN
 WITH "H" : HALOGEN FREE
 WITHOUT "L" :A:12.2
 WITH "L" : A:16.6
 COLOR:
 B:Black
 PLATING
 B: Tin PLATED
 Pin NO.
 02:2P
 Packing
 2:BAG

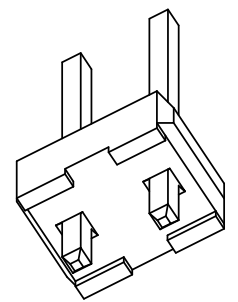
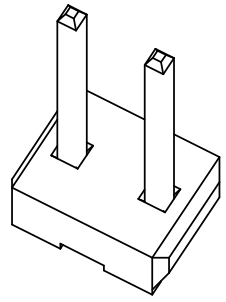
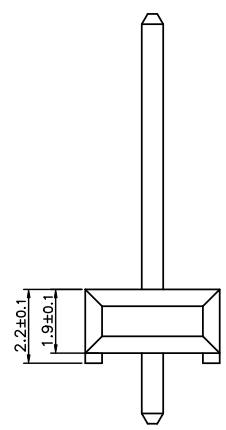
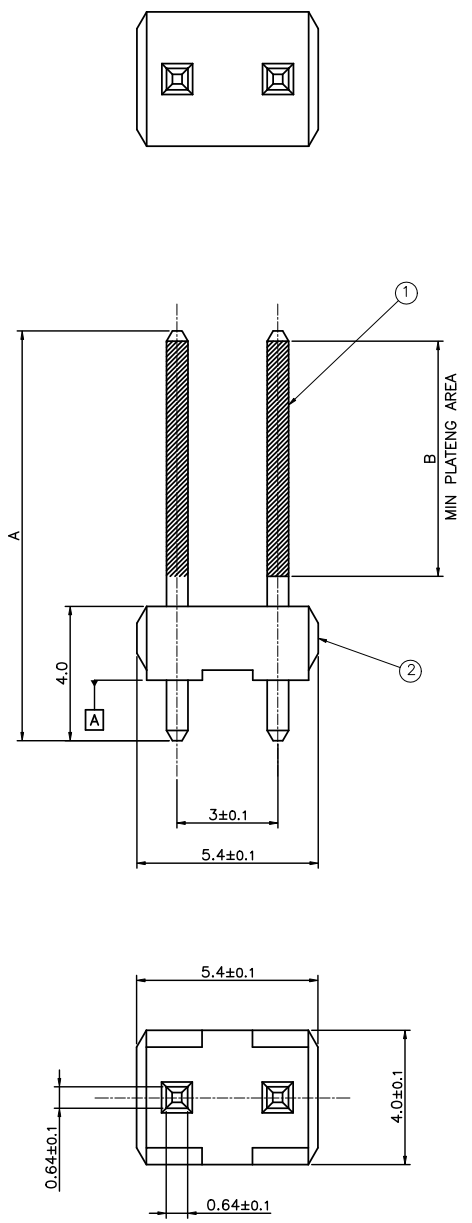

	DIM A	DIM B
PH3001H-XXXXX	12.2	7
PH3001H-XXXXXL	16.6	11.5

2	HOUSING	1	LCP	UL 94V-0 BLACK
1	SIGNAL TERMINAL	2	BRASS	T=0.64MM TIN
NO.	DESCRIPTION	Q'TY.	MATERIAL	

一般公差 TOLERANCES X ±1.0 .XX ±0.25 X ±0.5 .XXX ±0.2 ANGLES ±2°		希尔盛精密电子(昆山)有限公司		
檢驗尺寸標示 SYMBOLS ⊕ ⊗ INDICATE CLASSIFICATION DIMENSION ⊕ MARK IS CRITICAL DIM. ⊗ MARK IS MAJOR DIM.		品名 (TITLE) Pin Header,180°DIP,3.0mm Pitch 针长 12.2MM 双排 排针 圖號 (DWG NO.) C-PH3001H-XXXXXX		製圖 (DR) Leo_he 審核 (CHKD) YXL 核准 (APPD) YXL
表面處理 (FINISH)	比例 (SCALE) 1:1	單位 (UNITS) mm		張數 (SHEET) 1/1 SIZE A4 REV X1

A B C D E F